

	A	B	∅C	D	∅E	F	HM
IST 050-10	10	5	9.52	5.35	4.4	7.5	K05/K15/P25
IST 050-13	13	6	12.7	5.35	5.5	10	K05/K15/P25
IST 050-14	14.5	5	9.52	4	4.4	7	K05/K15/P25

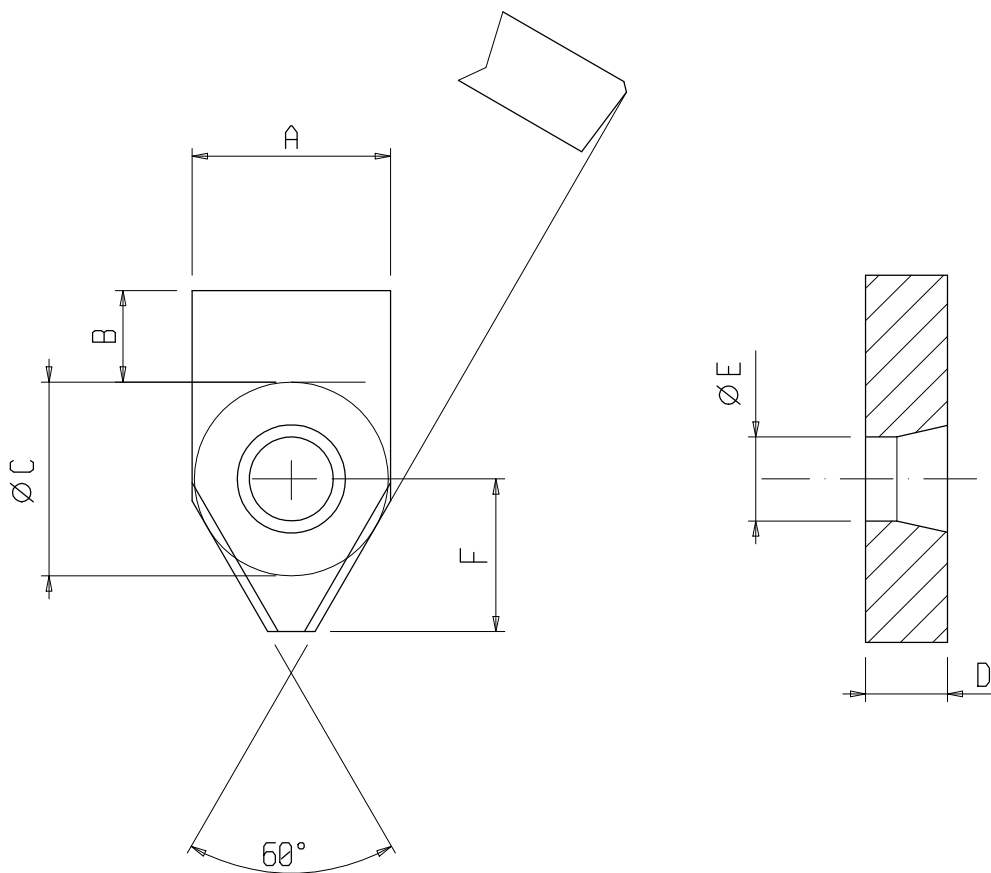

TOLL. GENER. +0.05 - -0.05

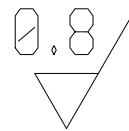

N°	Data	Diseg.	Modifica	TOLLERANZE GENERALI					
				Dimens. lineari mm	< 0.5	0.5-20	20-50	50-100	> 100
				Tolleranza micron	± 50	± 100	± 200	± 300	± 400
				Fori H13	Alberi h13	∠± 30'	◎± 100		
				Rugosità gen.	RA 3.2				
Diseg. Pecis E.			Partic. INSERTO HM						
Data 09/04/02			Materiale TIPO HM						
Lucido			TRATT.TERM. ,						
				N° Codice	IST050			Modifica	
								1	2
								4	5
								3	6